

LANCE AND FORM DOUBLE BRIDGE RADIUSED (CARD GUIDE)

TOOL CODE FV

24

ORDERING SPECIFICATIONS

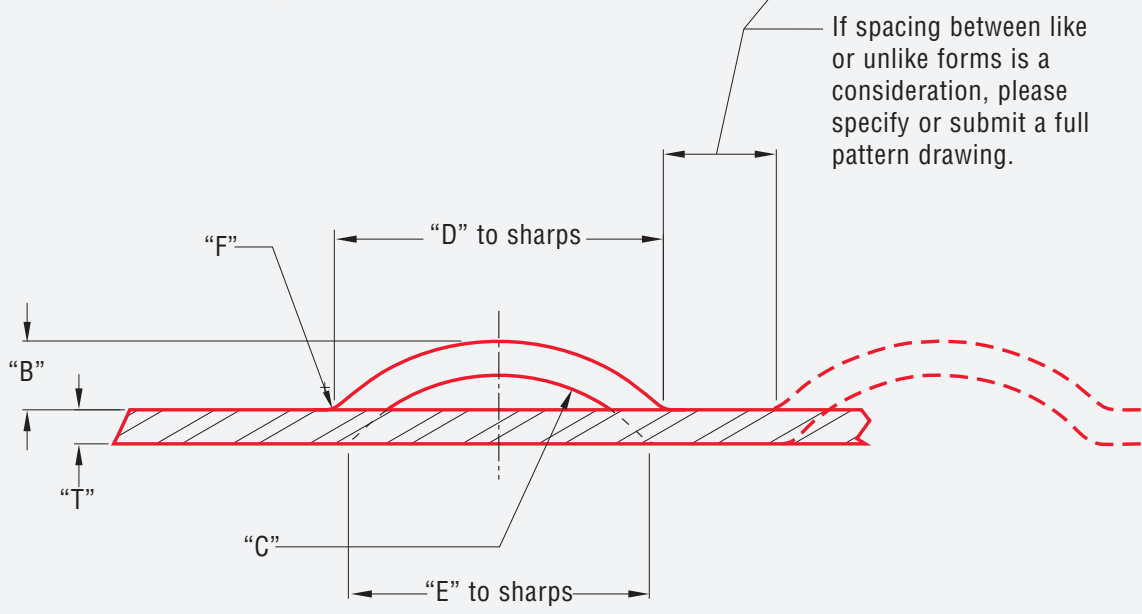
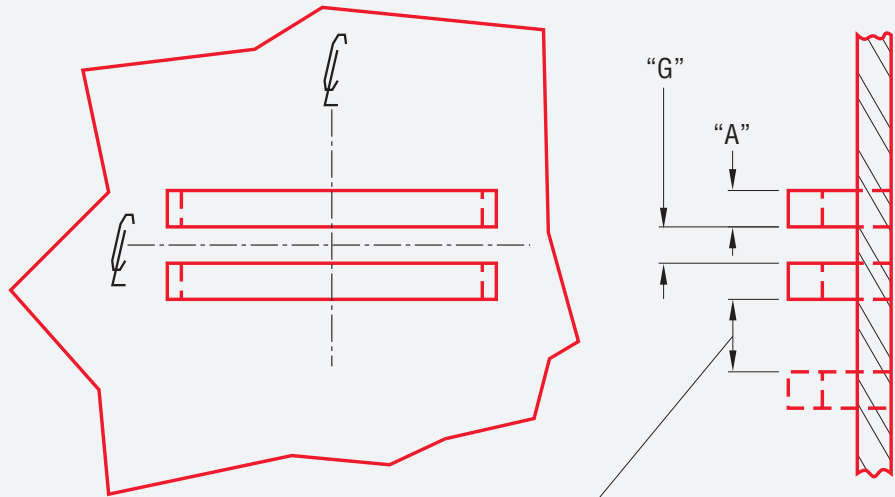

TOOL INFORMATION

Not all of the dimensions shown below are required. Fill in the critical dimensions and a Mate representative will contact you if more information is required.

A _____ F _____
 B _____ G _____
 C _____
 D _____
 E _____

GENERAL INFORMATION

Material Type _____
 Material Thickness "T" _____
 Machine Type _____
 Tooling Style _____
 Tooling Station _____
 Dimensions filled in by _____
 Approved By _____



Holland Precision Tooling BV
 Amsterdamsestraatweg 33 - 1411 AW Naarden
 Tel.: 035 - 539 90 90 - info@hptooling.nl

